

FTA : Purchase / Sub-Contract Manager



NEVILLE

PRECISION ENGINEERING LTD

UNIT 4A, PARK LANE BUSINESS PARK, KIRKBY-IN-ASHFIELD, NOTTS. NG17 9LE
TEL : 01623 722113 FAX : 01623 722118 WWW.NEVILLES.CO.UK

SPECIALISTS IN THE SUPPLY AND CNC MACHINING OF ALUMINIUM EXTRUSIONS

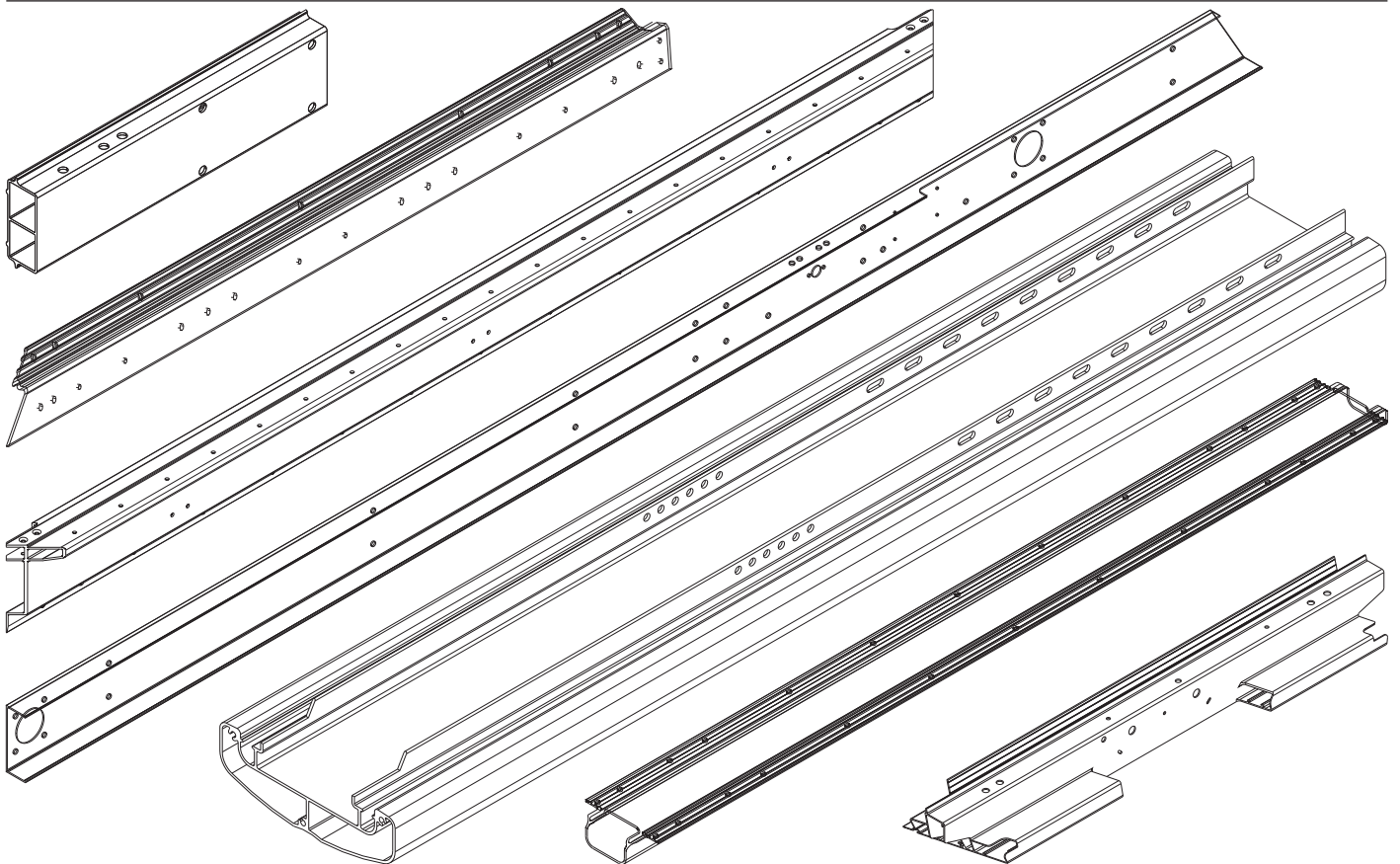

We can machine up to 8,000mm (3 Axis) and 6,700mm (4 Axis) in one operation without the need to index the material. We have 5 CNC milling machines in total plus a CNC double mitre saw for cutting sections up to 8,000mm in length. We work both as a subcontractor on free issue material for many of the extrusion mills, or source material directly on behalf of our customer providing a one stop shop for finished aluminium extruded components.

CIMAN MIRA - 6.7 MT CNC 4 AXIS VERTICAL MILLER
TEKNA 427 - 8 MT CNC 3 AXIS VERTICAL MILLER
TEKNA 426 - 3 MT CNC 4 AXIS VERTICAL MILLER
TEKNA 145 - 8 MT CNC DOUBLE MITRE SAW
BRIDGEPORT VMC 1000
BRIDGEPORT INT 1
MIG & TIG WELDING

**Please call for more
information and ask for :**

Edward Neville
(Managing Director)

Roy Laczanski
(Purchasing / Production)

Tel : 01623 722113